



729631 (E9BAPL00MP)

HP Ref-Freezer Base with 2 drawers, -22/+8° C - R290

Main Features

- Forced air circulation for rapid cooling and an even temperature distribution.
- Magnetic snap-in drawer gaskets are removable for cleaning.
- Suitable for use in ambient temperatures of up to 40 °C.
- Unit able to operate both as refrigerator or as freezer, with temperature range from -22°C to +8°C.
- Unit may be installed on castors.
- Exclusive **IcyHot** installation: combine 1200 mm PowerGrillsHP or NitroChrome3 Fry Top HP with the dual temperature ref/freezer base, obtaining a single appliance with higher productivity and more efficient cooking and storage operations.
- Heavy-duty stainless steel tubular drawer handles.
- Perforated top surface and bottom plate for a better air circulation.
- All major components may be easily accessed from the front.
- Designed for modular installation into the cooking block.
- Two Drawer Refrigerated/Freezer Base with built-in compressor unit
- Each drawer to accommodate one GN 2/1 container max 150 mm high.

Construction

- Constructed in Stainless steel with Scotch Brite finish to meet the highest hygiene standards.
- Built-in compressor to suit operating conditions.
- IPX3 protected.
- Large digital white-digit display with soft touch buttons.
- Supplied with 100 mm height adjustable feet.

Sustainability

- CFC and HCFC free, highly ecological refrigerant type: R290 (ecological gas in foam: cyclopentane). Hydrocarbon refrigerant gas R290 for the lowest environmental impact (GWP=3), to reduce green house and ozone depletion effects.



Optional Accessories

PNC Code	Description
Containers, trays and grids	
880249	Support GN container for refrigerated/freezer base
Feet, wheels and ramps	
880123	4 wheels - 2 with brake for re-Freezer Base, H=145mm - to be used only for standalone installation
880234	4 wheels, 2 with bakes, for Refrigerated and Freezer Base, H=125mm
Kicking strips	
880221	Pair of side kicking strips for refr-freezer base
880336	Frontal kicking strip for freezer/refrigerated base

Recommended Detergents

PNC Code	Description
OS2881	S01 STAINLESS STEEL SURFACE POLISHER; 6 BOTTLES X 750ML C/T
OS2883	S03 ALCOHOL BASE DETERGENT; 6 BOTTLES X 750ML; ADR&IMDG&IATA Limited Quantity
OS2884	S04 GLASSES & HARD SURFACES CLEANERS; 6 BOTTLES X 750ML
OS3257	S05 - MULTIPURPOSE DEGREASER; 6PCS X 750ML; ADR&IMDG Limited Quantity



Technical specifications

Electric

Supply voltage:	220-240 V/1 ph/50 Hz
Electrical power max.:	0.55 kW
Total Watts:	0.55 kW
Compressor power:	3/4 hp

Key Information:

External dimensions, Width:	1198 mm
External dimensions, Depth:	902 mm
External dimensions, Height:	627 mm
Net weight:	118 kg
Shipping weight (gross):	161 kg
Shipping height:	940 mm
Shipping width:	1050 mm
Shipping depth:	1400 mm
Shipping volume:	1.38 m ³

Sustainability

Current consumption:	4.2 Amps
Refrigeration power:	0 W
Refrigerant weight:	120 g

Front

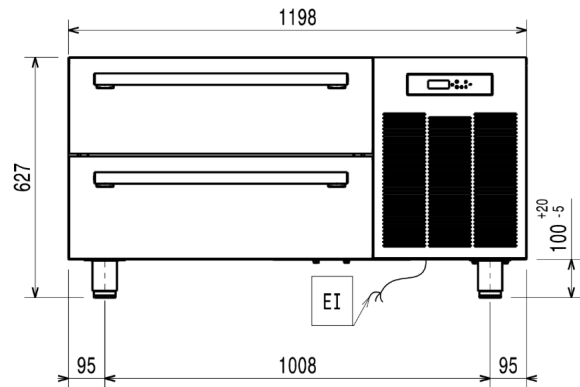

Side

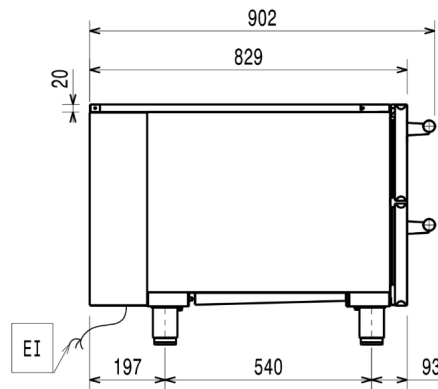

Top

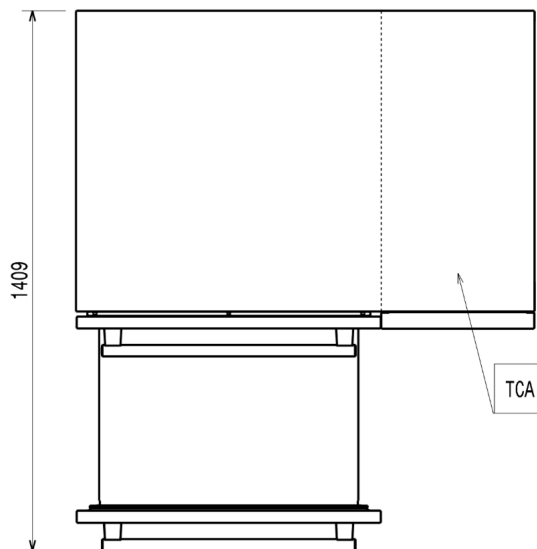

EI = Electrical inlet (power)



Find out more:
ISO Certificates
Electrolux Professional Recognitions

The company reserves the right to make modifications to the products without prior notice. All information correct at time of printing.

2026/05/11

3/3